



PORTE INTERNE - PUERTAS INTERNAS INNER DOORS - INNENTÜREN - PORTES INTÉRIEURES

ATTENZIONE: Per installazioni in condizioni ambientali e climatiche particolari (es. umide, acide, saline), consultare prima l'ufficio commerciale - CAUTION: For installations in particular environments or climate (ex. wet, acid, saline) consult sales office first

8010



BILOBA®

 0°-80°

 8÷13,52 mm

 1000mm

 MAX 100kg

 -15 °C
 +40 °C

- Cerniera oleodinamica con regolazione delle velocità di chiusura dell'anta. Stop a 0° +90° -90°. Adatta anche per porte in battuta.
- Bisagra cierra puerta hidráulica con ajuste de velocidad de cierre de la puerta. Freno a 0°, + 90°, -90°. Adecuada por puertas con tope.
- Hydraulic hinge with adjustment of the closing speed of the door. Stop at 0° +90° -90°. Suitable for doors with stop.
- Hydraulischcharnier mit Feststellung der Türschließgeschwindigkeit. Feststellung bei 0° +90° -90°. Für Anschlagtüren geeignet.
- Charnière hydraulique avec réglage de la vitesse de fermeture du battant. Arrêt à 0° +90° -90°. Adaptée également pour les portes avec butée.

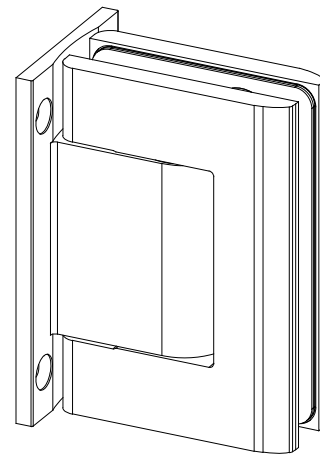

DISPONIBILE ANCHE NELLE VERSIONI: 1) SENZA FERMI A 90° PER GLI ART.8010, 8011 E 8015 - 2) "L" LIGHT CON MOLLA DEPOTENZIATA PER PORTE DI LARGHEZZA INFERIORE A 500 MM. Versioni da specificare in fase d'ordine e soggette a possibili minimi d'ordine. Per ulteriori informazioni contattare l'ufficio commerciale.

TAMBIEN DISPONIBLE: 1) SIN RETENCION A 90° POR LOS ARTICULOS 8010, 8011 Y 8015 - 2) "L" LIGHT - MUELLE CON MENOS FUERZA PARA PUERTAS INFERIORES A 500MM. Se tendrá que especificar en los pedidos y ser objeto de pedido mínimo. Nuestra oficina comercial está a su disposición para ampliar esta o cualquier otra información.

AVAILABLE IN FURTHER TWO VERSIONS: 1) WITHOUT 90° STOP FOR ITEMS 8010, 8011 AND 8015 - 2) "L" LIGHT WITH WEAKENED SPRING FOR DOORS WITH WIDTH LESS THAN 500MM. Both have to be specified on being ordered and could be subjected to minimum quantity order. For further information, please get in touch with the export department.

ES IST AUCH IN ANDEREN 2 VERSIONEN VERFÜGBAR: 1) OHNE 90° ARRETIERUNG FÜR ARTIKELNUMMER 8010, 8011 UND 8015 - 2) "L" LIGHT MIT SCHWÄCHERER FEDER FÜR TÜREN UNTER 500 MM. Beide sind bei der bestellung anzugeben und könnten eine mindestbestellmenge verlangen. Für weitere informationen setzen sie sich mit unserer exportabteilung im kontakt.

DISPONIBLE EGALEMENT EN VERSION: 1) SANS BUTÉE A 90° POUR LES ART.8010, 8011 E 8015 - 2) "L" LIGHT AVEC RESSORT DE FAIBLE PUISSANCE POUR LES PORTES D'UNE LARGEUR INFERIEURE A 700 MM POUR L'ART.8060. Versions a préciser lors de la commande, éventuellement soumises à des quantités minimum. Pour d'autres informations, veuillez contacter le service commercial.

Classificazione secondo normativa - Clasificación según la ley - Classification according to int'l regulation Klassifizierung nach den Vorschriften - Classification selon la norme						
art. 8010	UNI EN 1154:2006	3	8	$\frac{2}{5}$	0	1 4

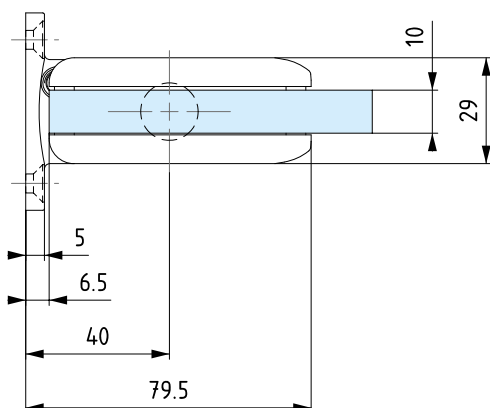
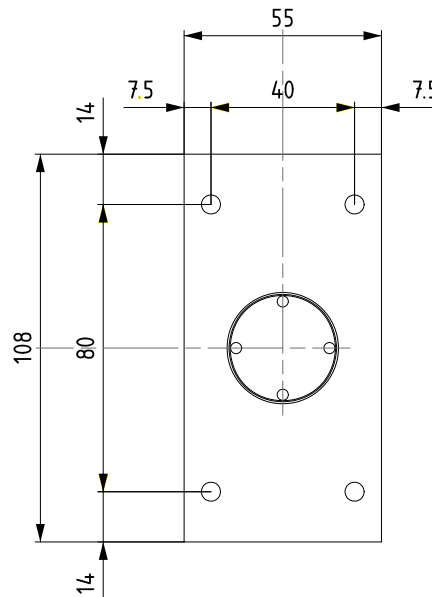
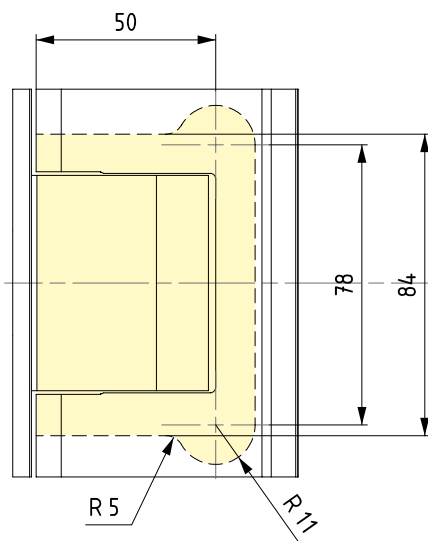

Valvola di regolazione velocità chiusura anta
Adjustment valve for the door's closing speed

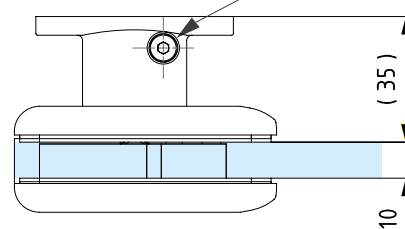

TESTATA 1.000.000 CICLI
TESTED FOR 1.000.000 CYCLES